

setting the  
standard  
for **energy**  
**recovery**

---



**THERMOGAIN**  
HEAT EXCHANGER

---

*The most reliable air-to-air energy recovery component*



**innergy**  
**tech**

# YOUR GUIDE

## TO THE ENERGY RECOVERY WORLD

---

With their long life expectancy, individually charged and sealed tube construction with integrally turned fins and no moving parts, the Thermogains are known to be the most reliable air-to-air energy recovery components.

Very easy to clean thanks to their integral fins increased rigidity, our Thermogains heat pipes represent an excellent choice for dirty air stream applications. With their compact sizes and rectangular shape, their incorporation to HVAC systems is also greatly simplified.

### Features and benefits

- High effectiveness for rapid payback
- No operating costs
- No external power required
- Wide selection of custom made models for different applications
- No moving parts for virtually maintenance free operation
- Tough and easy to clean product
- Integral fin tube technology for no tube-to-fin bond resistance.
- Physical separation of air streams preventing cross contamination
- Various coatings available to protect the unit against a variety of exhaust air conditions
- 100% aluminum tubes with extruded fins (no assembly) means no possible galvanic or crevice corrosion.
- UL 207 certified (Standard for Refrigerant-Containing Components, Nonelectrical)
- CSA C22.2#140.3 Refrigerant-Containing Components for Use in Electrical Equipment
- Software is available for easy selection and design characteristics

setting the  
standard  
for **energy**  
**recovery**

# WHAT IS A THERMOGAIN HEAT PIPE?

The Thermogain heat pipe is a self-contained self-maintaining passive energy recovery device. It has a very high coefficient of thermal transfer utilizing vapor liquid flows. What's more amazing is that heat pipes have no moving parts, require no external energy (other than the heat they transfer), they are reversible in operation and are completely silent. Like any other piece of tubing or pipe, they are rugged and can withstand a lot of abuse.

A heat pipe consists of three elements: a sealed container, a capillary wick structure and sufficient working fluid to saturate the wick structure. Because the container is vacuum sealed, the working fluid is in equilibrium with its own vapor. Heating any part of the external surface, causes instantaneous evaporation of the working fluid near that surface (the evaporator region) with the latent heat of vaporization absorbed by the vapor formed.

The rapid generation of vapor at any point on the tube wall area creates a pressure gradient within the heat pipe which forces the excess vapor to the other side area of the pipe having a lower pressure and temperature.

Once on the other side, the vapor condenses on the tube wall and the latent heat of vaporization is transferred (the condenser region).

Heat is removed from the surface at the point of condensation by conduction, convection or radiation. A continuous process is established by the capillary pumping forces within the wick structure, thus returning the fluid to the evaporator section. In effect, we have a perpetual motion machine with no moving parts and requiring no energy of its own. Each heat pipe has a transfer efficiency of 99.3%.

## How does a THERMOGAIN heat recovery unit operate?

The Thermogain pipe heat exchanger is constructed of individual tubes, each tested and inspected to insure peak performance. The exchanger provides a simple, efficient and compact method of air-to-air heat recovery. Thermogain heat pipe resembles conventional heating and cooling coils, however has several important differences:

1. A partition divides the exchanger into two sections, to ensure the separation of the supply and exhaust air flows.
2. The Thermogain heat pipe recovers heat from the hot air stream and transfers it to the cold air stream in a counter flow arrangement. All of its tubes are totally independent systems and require no external source of power.

While Thermogain can recover up to 70% of exhaust air heat under ideal conditions, the economical heat recovery rate is between 50 and 60%. This represents a tremendous saving of heating and cooling costs. In addition, the Thermogain heat pipe is a fully reversible system for great summer and winter energy recovery without the need of complicated tilt mechanisms or solenoid valves.

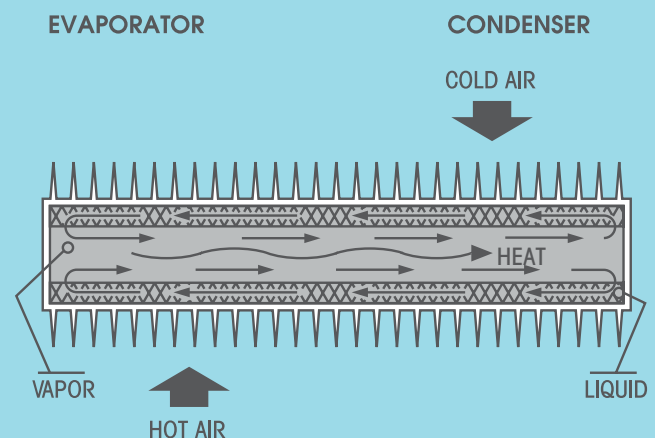

# HVAC

## HEAT RECOVERY APPLICATION

The Thermogain heat exchanger installed in a ventilation system recovers heat from the stale outgoing air and transfers it to the fresh incoming air. It represents a simple, yet effective way of providing continuous fresh air in the building throughout the winter and summer months.

### Industrial heat recovery applications

Thanks to its rugged and easy to clean construction, the Thermogain heat pipe is an excellent choice for industrial applications with dirty airflows. Available with various fins per inch and rows, the Thermogain heat pipe can be easily adjusted to reach a specific effectiveness or pressure drop. The optional Heresite or Electrofin coatings also makes it an excellent choice for corrosive environments.

### Return to process heat recovery

Heat from the exhaust is recovered and returned as preheated air to the process (oven, dryer, etc.)

### Process to process heat recovery

Recovered heat from one process is returned to another process or heating system. It is sometimes possible to completely heat a second process with the recovered heat from the first and totally eliminates the power source.

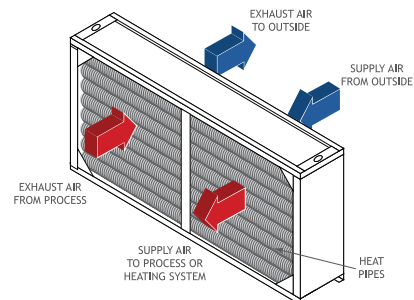
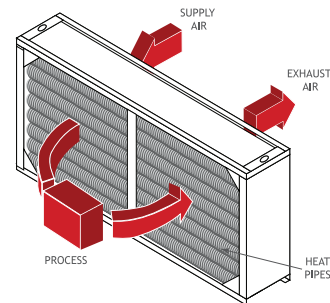
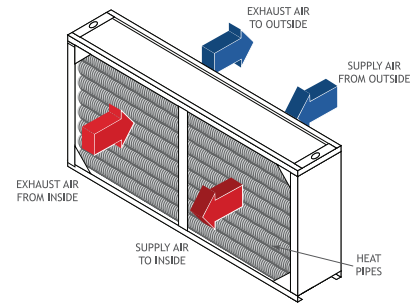

# THERMOGAIN

## HEAT RECOVERY UNIT CONSTRUCTION FEATURES

Thermogain units are constructed with aluminum tubes which have an inside diameter of 1 inch (2.5 cm) and a thickness of .166 inch (.422 cm). A unique feature of the heat pipe is that the fins are of an integral spiral fin design. Integral fin construction gives significant advantages over plate fin or duplex finned designs. These advantages are extremely important. The fins are an integral part of the heat pipe container wall, the fin material is continuous with the tube and thereby eliminates bond resistance, uneven thermal expansion, and significantly decreases maintenance. The integral fin heat pipe provides maximum heat transfer with minimum pressure drop while providing extended life without fear of fin-tube separation due to thermal cycling. The entire assembly is contained in a rugged galvanized steel frame and comes supplied with galvanized steel dust covers at both ends (304 or 316 stainless steel optional). Design features of the Thermogain heat recovery unit are:

1. Individual heat pipes generate higher reliability because each pipe is not depending upon another for operation.
2. Ease of cleaning because integral fin construction allows for greater fin spacing without loss of efficiency.
3. Thermal expansion - Each heat pipe is individual within the frame, thereby eliminating bonding problems found in expanded tube design. Pipe distortion is also eliminated.
4. Counter flow design provides maximum effectiveness.
5. Large selection of sizes and effectiveness to meet customer needs.
6. Rugged design to reduce maintenance requirements.
7. Bi-directional for use in HVAC applications.
8. Silent. Does not add to the noise in the plant.
9. Passive recovery device, no energy to save energy.
10. Anti-corrosive Heresite or Electrofin coatings are available for designs requiring protection against corrosive exhaust air.

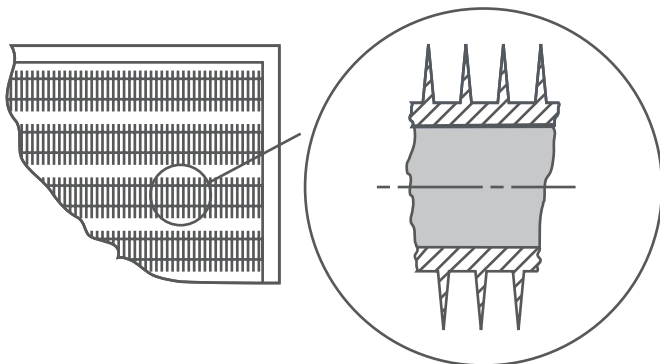

**IFA    22TF    108L    9FPI    4    4R OPTIONS**  
**1        2        3        4        5**

### Model number selection

Select Heat Exchanger Model #

**IFA    22TF    108L    9FPI    4R    OPTIONS**

	<b>1</b>	<b>2</b>	<b>3</b>	<b>4</b>	<b>5</b>	
<b>1. Integral Finned Aluminium</b> _____	_____	_____	_____	_____	_____	_____
<b>2. Number of Tubes in Face of Exchanger</b> _____	_____	_____	_____	_____	_____	_____
<b>3. Finned Length of Exchanger</b> _____	_____	_____	_____	_____	_____	_____
<b>4. Fins per inch</b> _____	_____	_____	_____	_____	_____	_____
<b>5. Row depth of Exchanger</b> _____	_____	_____	_____	_____	_____	_____
<b>Options :</b> _____	_____	_____	_____	_____	_____	_____

- H: Heresite coating (full)
- E: Electrofin E-coat coating (full)
- EC: E-coat (casing only)
- DXX: Unsymmetrical heat pipe with XX being the supply fin length
- DP: Double "Lab seal" partition
- V: Vertical installations
- SS1: 304 stainless steel casing
- SS2: 316 stainless steel casing

# INSTALLATION CONSIDERATIONS.

## Installation of the unit:

Recommendation for installation: The Thermogain unit should be installed so that both fluids will be drawn up through the recovery cell.

## Leveling exchanger:

The Thermogain heat exchangers could be installed level, according to the manufacturers specifications.

The exhaust section must be installed lower, when used only for heating.

## Supporting structure:

The exchangers should be secured rigidly, not to allow more than 1/8 inch (.32 cm) total deflection. The supply duct must never be fixed directly to the Thermogain frame.

A support structure can be made to slide the unit for cleaning and installation purposes. We recommend the following practices:

1. Blades on face dampers should always be perpendicular to the tubes.
2. Electric preheat coils, when required, should be a minimum of 3 feet (.9 m) upstream from the exchanger face on the supply side.

## Filtration requirements:

Performance specifications are based upon clean air and a clean surface. It is required that adequate filtration be used in both air streams to insure optimum performance and minimum maintenance.

## Access doors:

Access doors should be provided to allow periodic inspection of the exchanger and to facilitate cleaning when necessary.

## Drain pans:

Sloped drain pans are recommended under the entire exchanger both as a condensed collection system and for cleaning purposes.

## Code requirements:

The installation of the exchanger should conform to all codes, laws and regulations applying at the job site.

## HVAC Heat Pipe HeatExchanger Specifications.

### 1. GENERAL SPECIFICATIONS:

a) Furnish and install the Thermogain heat recovery units of the heat pipe air-to-air type as shown in the schedule, to be manufactured by Innergy Tech inc., Drummondville, Quebec, Canada.

- b) Thermogain heat recovery units shall transfer heat between outgoing and incoming air streams in counter flow arrangement.
- c) Thermogain heat recovery units must be installed level when used for heating and cooling energy recovery.
- d) Thermogain heat recovery units are labeled for direction of air flows, exhaust inlets and outlets and supply flange connections and a tilt angle.

### 2. HEAT PIPE HEAT EXCHANGER SPECIFICATIONS:

- 2.1 Tube core shall be 1 inch (25.4 mm) ID seamless, integrally finned aluminum 1050 tube with 0.058 inch (1.5mm) wall thickness. Tubes shall use heights increments of 2-1/8 inches (54 mm) maximum and the spacing between rows shall be no more than 1 7/8 inch (48 mm).
- 2.2 Fin surface shall be integral to the tube wall and shall have a minimum of .017 inch (.043 mm) between fins. Heat pipes using different materials for the fins and tubes are not acceptable.
- 2.3 Acceptable Fin densities are 11, 9, 7 or 5 fins per inch. Fin height from root to tip shall be .437 inch (11 mm) minimum.
- 2.4 Circumferential capillary wick structure shall be integral to the inside of the tube wall.
- 2.4 Working fluids used shall be selected on the basis of the heat pipe operating temperatures and compatibility with tube and wick materials.
- 2.5 Working fluid must have an ozone depleting potential of 0 and global warming potential of 1400 or lower.
- 2.6 Tubes shall be individually processed, charged, hermetically sealed and factory tested for leakage.
- 2.7 The exchanger frame shall be fabricated from minimum of 14 gauge galvanized steel. The frame shall be supplied with minimum 2 inches (51 mm) flanges on all four sides. Intermediate tube supports shall be furnished as required.
- 2.8 A partition shall be provided to isolate the outgoing and incoming air streams; there shall be no cross contamination. The partition shall be located in the center of the heat pipe unless otherwise specified. Partition shall be fabricated from a minimum of 14 gauge galvanized steel and shall be extended beyond the finned surface with the help of 4 inches (102 mm) flanges on both the supply and exhaust sides. Both front and back flanges to be flush with the frame.
- 2.9 End covers shall be provided to protect tube ends. Covers shall be fabricated in 16 gauge galvanized steel.
- 2.10 When protective coating is required, a baked phenolic coating to protect against corrosion must be applied. Coating to be factory applied to supply and/or exhaust sides.

# EXCHANGER

## DIMENSION DATA

L		Overall length L'	
Inch	Cm	Inch	Cm
24	61.0	30	76.2
36	91.4	42	106.7
48	121.9	54	137.2
60	152.4	66	167.6
72	182.9	78	198.1
84	213.4	90	228.6
96	243.8	102	259.1
108	274.3	114	289.6
120	304.8	126	320.0
132	335.3	138	350.5
144	365.8	150	381.0
156	396.2	162	411.5
168	426.7	174	442.0
180	457.2	186	472.4
192	487.7	198	502.9
204	518.2	210	533.4
216	548.6	222	563.9
228	579.1	234	594.4
240	609.6	246	624.8

ROWS	Overall length W		FIN DEPTH	
	Inch	Cm	Inch	Cm
2	5 7/8	14.9	4	10.16
3	7 3/4	19.7	5 7/8	14.9
4	9 5/8	24.4	7 3/4	19.7
5	11 1/2	29.2	9 5/8	24.4
6	13 3/8	34.0	11 1/2	29.2
7	15 1/4	38.7	13 3/8	34.0
8	17 1/8	43.5	15 1/4	38.7

VALUE OF X		
L = FEET	2' - 14'	15' - 20'
M	.609 - 4.26	4.57 - 6.09
X = IN.	2"	3"
CM	5.08	7.62

TUBES IN FACE	H		OVERALL HEIGHT			
			L = 2' à 14'		L = 15' à 20'	
	Inch	Cm	H'		H'	
	Inch	Cm	Inch	Cm	Inch	Cm
7	14 7/8	37.8	18 7/8	47.9	20 7/8	53.0
10	21 1/4	54.0	25 1/4	64.1	27 1/4	69.0
13	27 5/8	70.2	31 5/8	80.3	33 5/8	85.4
16	34	86.4	38	96.5	40	101.6
19	40 3/8	102.6	44 3/8	112.7	46 3/8	117.8
22	46 3/4	118.7	50 3/4	128.9	52 3/4	134
25	53 1/8	134.9	57 1/8	145.1	59 1/8	150.2
28	59 1/2	151.1	63 1/2	161.3	65 1/2	166.4
30	63 3/4	161.9	67 3/4	172.0	69 3/4	177.1
32	68	172.7	72	182.9	74	187.9

TYPE IFA (1" I.D.)  
 ROWS 2-3-4-5-6-7-8  
 ADDITIONAL SUPPORTS  
 AS REQ'D.

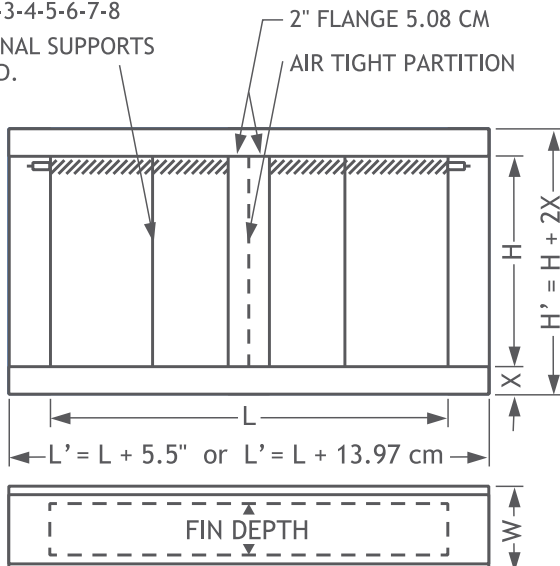

# setting the standard for **energy recovery**



Innergy tech –a market leader in energy recovery components. Innergy tech, a company based in Canada, has 20 years of experience in research, development and production of energy recovery components. Our units are highly efficient air-to-air energy recovery devices reducing energy losses in HVAC and industrial process applications. Our product line includes sensible (plastic and aluminum) and enthalpy plate exchangers, heat pipes and energy recovery wheels. Our products offer innovative and cost effective solutions that can be easily integrated to any energy recovery ventilation system.

#### **Guaranteed effectiveness with AHRI 1060 Certification Seal.**

Innergy tech components are tested independently and proven to be one of the most efficient energy recovery devices on the market. Our units are AHRI 1060 certified under the Air-to-Air Energy Recovery Ventilation Equipment Certification Program and bear the AHRI 1060 Performance Certification seal.

#### **ETL Certified Product.**

The ETL Certified Mark is proof of product compliance to North American and Canadian Safety Standards. ETL Certified means that the product has not only been tested but also meets additional criteria set by the Manufacture.

#### **Automatic production to customer specification.**

Innergy tech components are manufactured to customer specification. State-of-the-art machinery ensures constant high quality products.